

# Marine Applications



**CRYODYNAMICS**  
SUBMERGED CRYOGENIC PUMPS & EXPANDERS

## Elliott Group, Cryodynamic Products

is the premier manufacturer of cryogenic pumps and expanders for the worldwide liquefied gas industry. Cryodynamics® pumps and expanders are the result of over 40 years of continuous engineering advancement. With the largest cryogenic test stand in the world, Cryodynamic Products is the only manufacturer of its kind with the knowledge and expertise to provide the most complete catalog of both standard and custom cryogenic pump equipment in the world.



## MARINE APPLICATIONS

Cryodynamic Products offers complete packages for all of your marine pump requirements. Units are available for all shipboard and floating applications, including main cargo unloading, stripping/spray, fuel and emergency (retractable), high-pressure, and expander services.

Flow capacities range from 5 to 3,000 m<sup>3</sup>/hr with heads available over 200 meters. Included are electric power feed cables and deck assemblies custom manufactured to meet all requirements of major ship classification societies. Special designs with built-in internal filtration are available to handle cargo that is likely to suffer particulate contamination, such as liquefied petroleum gas (LPG).

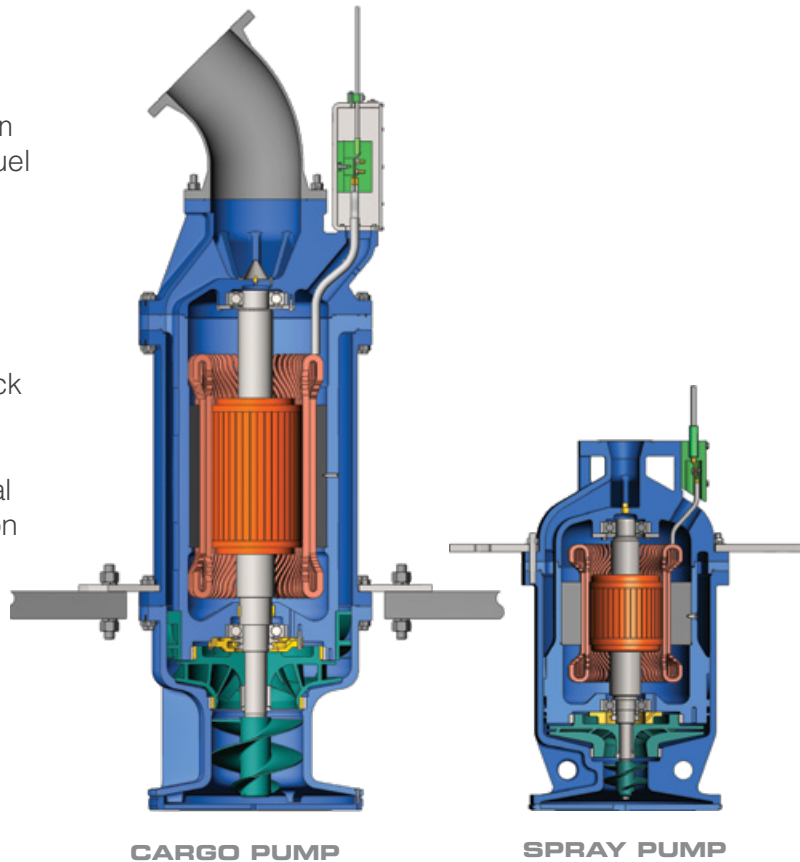



**EMERGENCY PUMP AFTER TESTING**



**MOUNTED SHIPBOARD SPRAY PUMP**



**MADRID SPIRIT LNG TANKER**

# CARGO PUMPS

## CARGO PUMPS

Cargo pumps are used to offload liquefied natural gas (LNG) at the import terminal. Efficient offloading - less than 12 hours - allows the ship to quickly return for the next load of LNG. Cryodynamics pumps are designed to draw down the tank liquid, leaving as little LNG in the tank as possible, reducing the amount of remnant LNG returned to the source, and increasing the amount efficiently delivered as usable LNG.

Cryodynamics cargo pumps are available in single- and multi-stage designs for bunkering, LNG, liquefied energy gas (LEG), and high-capacity applications. Full performance testing is offered.

## SPRAY (STRIPPING) PUMPS

Spray/stripping pumps spray LNG onto the inside top of the cargo tanks to help keep them cold and reduce boil-off gas vapor. Cryodynamics spray/stripping pump designs have an extremely low net positive suction head required (NPSHR), allowing cargo tanks to be offloaded to minimum liquid levels.

## EMERGENCY PUMPS

In the highly unlikely event that both cargo pumps were to fail on board, an emergency pump can be used to empty the stranded LNG from the cargo pump storage tank. Thousands of Cryodynamics cargo pumps have been delivered and there is no history of any of our emergency pumps ever being used due to pump failure, a testament to the reliability of the design.

## FUEL PUMPS

Cryodynamic Products has developed low-flow, high-head LNG fuel pumps to feed ship engines with clean, efficient LNG. These submerged pumps are designed to meet the rigorous conditions of marine fueling applications, and their rugged construction allows years of uninterrupted service, even while operating with fuels containing some amount of contamination.



## PUMP CHARACTERISTICS

	Flow Rate (m <sup>3</sup> /h)	Head (m)	Electric Motor (kW)	NPSHR (m)	Hydraulic Efficiency
HIGH FLOW CARGO PUMP 16EC-24H	1700-2400	150-200	<912	<1.00	83%
CARGO PUMP 16EC-24	1400-1950	140-180	<635	<1.00	82%
CARGO PUMP 12EC-24	1000-1500	125-170	<500	<1.00	82%
STRIPPING/SPRAY PUMP 2EC-12	42-62*	135-180	<26	<0.42	56%
FUEL GAS PUMP 1.25EC-083	13-19*	120-230	<12	<0.19	48%
EMERGENCY CARGO PUMP 8ECR-12	400-590	145-170	<190	<1.8	74%

\*Additional models available

## PUMP FEATURES

	Designation	Installation	Accessories	Application
HIGH FLOW CARGO PUMP 16EC-24H	In-Tank, Fixed	Bracketed to Tower	Single Flange Connection	Offloading Cargo
CARGO PUMP 16EC-24	In-Tank, Fixed	Bracketed to Tower	Single Flange Connection	Offloading Cargo
CARGO PUMP 12EC-24	In-Tank, Fixed	Bracketed to Tower	Single Flange Connection	Offloading Cargo
STRIPPING/SPRAY PUMP 2EC-12	In-Tank, Fixed	Bracketed to Tower	Single Flange Connection	Tank Cooling Stripping Tank
FUEL GAS PUMP 1.25EC-083	In-Tank, Fixed	Bracketed to Tower	Single Flange Connection	Fuel Supply to Engines
EMERGENCY CARGO PUMP 8ECR-12	In-Tank Retractable	In-Tank, Vertical	Foot valve, cable support system, headplate, deck junction boxes, storage containers	Back-up Pump for Cargo Pumps

# FLOATING



## FSRU APPLICATIONS

Cryodynamics submerged motor pumps are well suited for floating, storage, and regasification unit (FSRU) applications. Our Regas Package provides a combination of pumps for cargo offloading, stripping & spraying tanks, in-tank regas feed pumps, and high-pressure booster pumps to feed the vaporizers.

## FLNG/LIQUEFACTION, PRODUCTION, AND STORAGE

Whether it's a small or mid-scale floating liquid natural gas (FLNG) vessel, Cryodynamic Products has supplied pumps for these applications. Both tank-mounted and column retractable pumps are available. Process pumps for LNG, propane, butane, and ethane are also available.

## EXPANDERS

For many years, the traditional method to let down pressure in a liquid stream was a Joule-Thomson (JT) valve. The let-down process can be improved by replacing the JT valve with an expander, which will increase overall plant efficiency, reduce operating costs, and increase LNG production. The benefits include:

- Expanders increase production of liquefied gas by ~20 tonnes per day.
- Each megawatt of generated power increases the LNG production by ~60,000 tonnes per year.
- Expanders remove otherwise wasted energy from the LNG stream, decreasing the total power consumption and further cooling the cryogenic fluid.



## EXPANDER REGENERATIVE APPLICATION

Cryodynamic Products used medium voltage AC drives to provide the first LNG expander regenerative application for a marine project. The drive capability of the medium voltage drive enhanced the operating capability of the LNG expander. This allowed the LNG expander to be optimized for peak efficiency in the liquefaction process of the FLNG. It also allowed it to operate at varying conditions. The purpose-built drive was designed for Class Society Approval, specifically for the harsh marine environment.

Examples of the types of drives that can be used in these applications are:

The Allen-Bradley PowerFlex®\* 7000 Medium Voltage AC Drive:

<http://ab.rockwellautomation.com/Drives/Medium-Voltage>

## REGASIFICATION - HIGH-PRESSURE PUMPS

High-pressure pumps can be used for any regasification system to feed a vaporizer, and can be customized to meet project specifications. Typical pump discharge pressures are around 100 Barg and higher.

The reliable pump design improves system efficiency, reduces power consumption, and provides for continuous, long-term operation. New pump support tool technology offers easy installation and removal. A pump-mounted vibration monitoring system (VMS) is offered as a reliable and accurate vibration monitoring option.



## REGASIFICATION - FEED PUMPS

Feed pumps can be used to transfer LNG from the cargo tanks to the regasification system. Typically, retractable designs are used inside of a tank column and seated in the suction valve (foot valve).

The deep suction valve design keeps the pump tightly secured and prevents pump movement while at sea. A rigid pipe stabilization design feature is available to ensure the pump remains tightly in place. The high efficiency design offers low NPSHR to maximum liquid transfer. A pump-mounted VMS is a reliable and accurate vibration monitoring option.

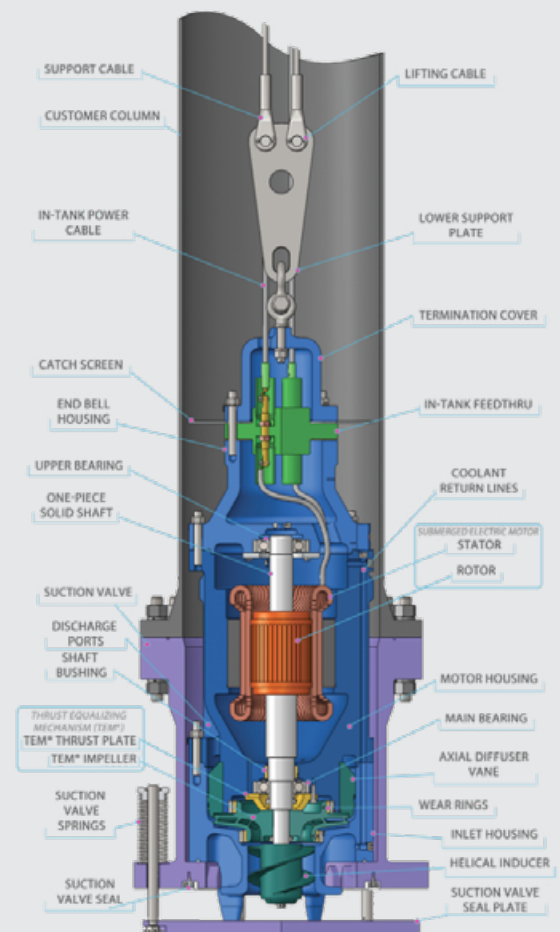

\*PowerFlex is a trademark of Rockwell Automation, Inc.

# PETROCHEMICAL

## GAS SHIPPING APPLICATIONS

Submerged motor pumps can be used for many gas shipping applications including LNG, LEG, and LPG. Additional applications may include ammonia, liquid nitrogen (LN<sub>2</sub>) and liquid hydrogen (LH<sub>2</sub>).

The pump motor in this design is submerged in the oxygen-free cryogenic liquid, removing the potential for ignition by the motor. Additionally, electrical connections in the hazardous area zones follow strict compliance regulations.

No rotating seals are needed, thus eliminating a source of gas leakage. This also allows the submerged motor design to safely accommodate caustic chemicals such as ammonia. The amount of downtime required for maintenance is reduced due to proper sealing of hazardous vapors. The pump rotating shaft assembly is connected directly to the motor on a single shaft. The bearings and the motor are cooled and lubricated by the pumping fluid, eliminating maintenance and potential failure of the external lubrication systems.

Cryodynamics next-generation multi-fluid cargo pump is the first supplied submerged motor pump designed to handle multiple cargos including ethane, propylene, propane, and butane, as well as LNG. The broad temperature range of these liquefied hydrocarbons is 100oC. The pump allows for an even broader range of hydrocarbon liquids, ranging from the coldest LNG (165°C) to ISO-butane (+0°C).

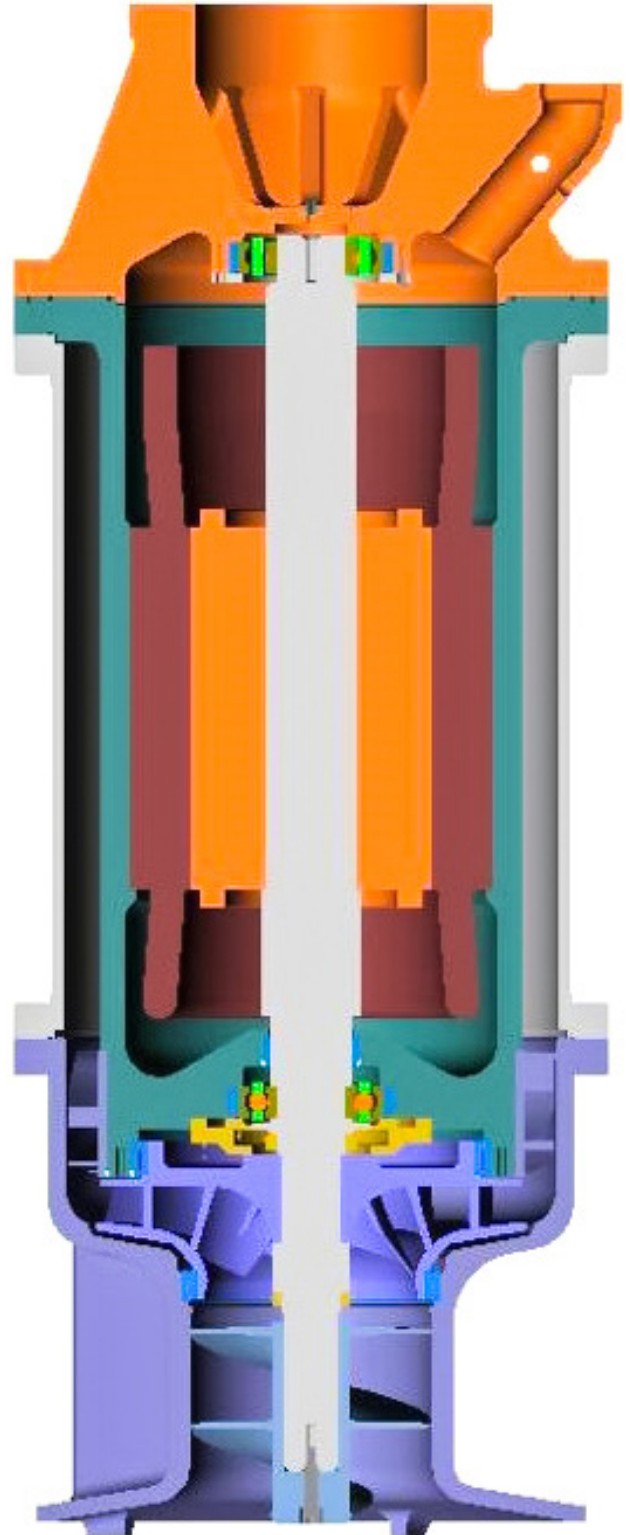



## CARGO RATED FLOW AND DIFFERENTIAL PRESSURE

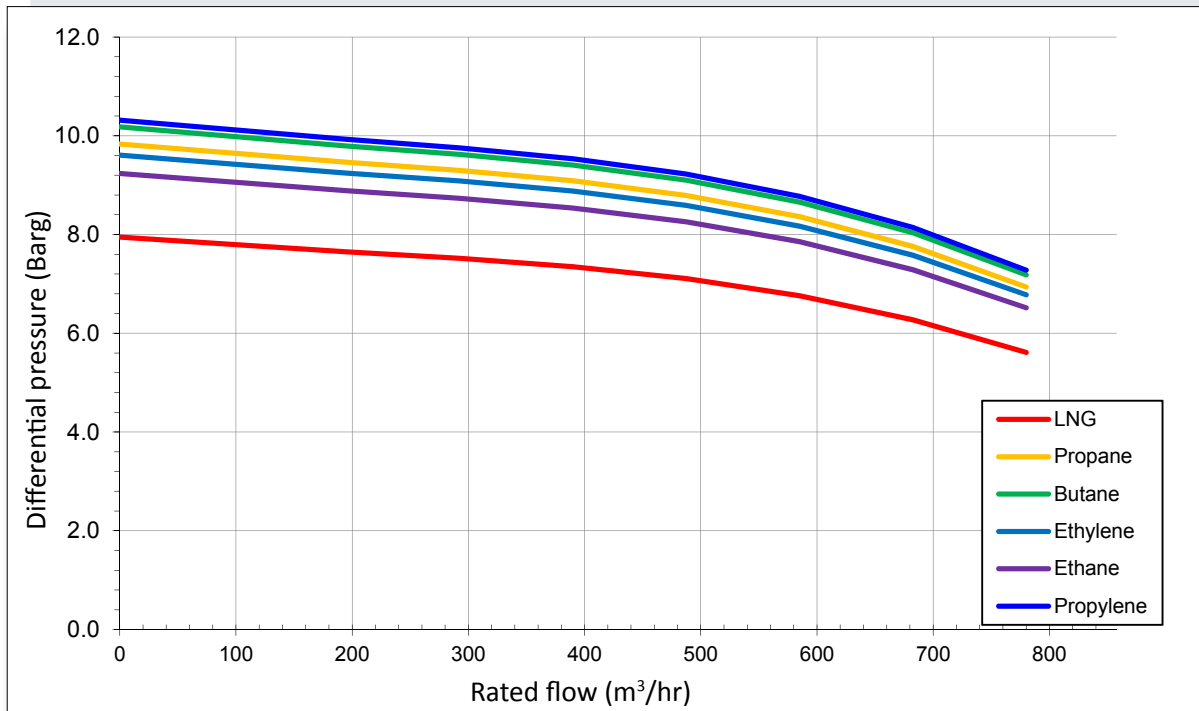

## PUMP APPLICATIONS

Liquid	Temperature (°C)	Density (kg/m³)
LNG	-163	470
Ethylene	-104	566
Ethane	-90	570
LPG*	-40	493/600
Propylene	-48	511
ISO-Butane**	-11	594
N-Butane**	+0	602

\*Note: Assumes mixture of propane/butane product. For pure butane product, modifications are required.

\*\*Note: Range of butane products can vary. Cryodynamic Products limits pump temperature to +0°C for butane products.

# FUEL GAS PUMPS

## SMALL SCALE APPLICATIONS

Cryodynamic Products developed the first dedicated LNG fuel gas pump for LNG carriers over 30 years ago. Today, we are developing fuel gas pumps for LNG-as-a-Fuel or LNG-powered market segments. Used in fuel gas supply systems (FGSS) or LNG fuel tank services, these pumps are designed to achieve lower capacity and higher pressure in response to current engine requirements and the need for maximum fuel efficiency.

The new CRYO-Fuel™ gas pump is designed specifically to maximize capacity range by using variable speed technology. The pump's operating duty can be set by varying the speed to meet capacity requirements ranging as low as 3 m<sup>3</sup>/hr up to 20 m<sup>3</sup>/hr, and pressure requirements from as low as 5 Barg up to 22 Barg. Designed for LNG at a density of 500 kg/m<sup>3</sup>, the motor is rated to handle the pump maximum allowable working pressure (MAWP).

Cryodynamic Products also carries standard fuel pumps for low-pressure applications. Custom designs for higher pressure applications are available also.

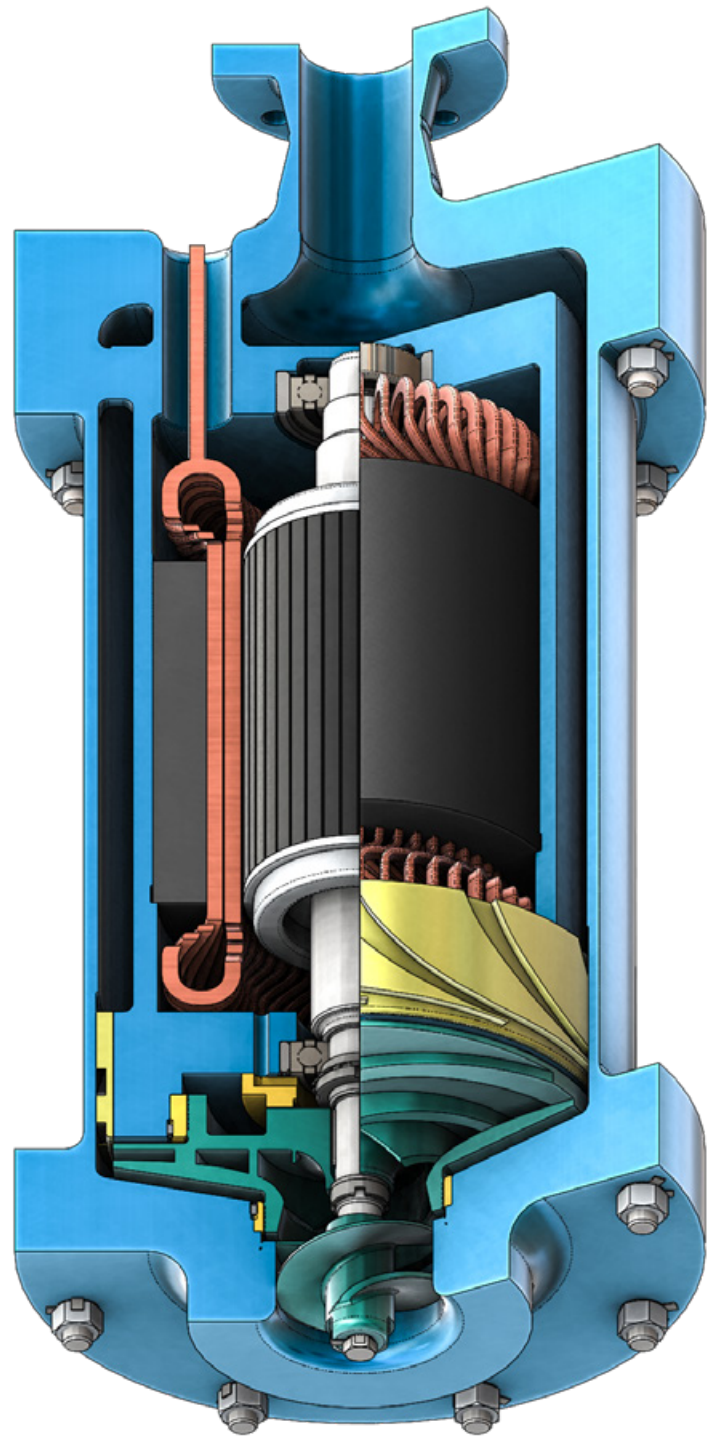

## FUEL GAS PUMP CHARACTERISTICS

	Low Flow	Medium Flow Two Stage	Medium Flow Three Stage	Higher Flow
<b>Model:</b>	1EC-063	1.25EC-082	1.25EC-083	1.5EC-092
<b>Capacity:</b>	7-11 m <sup>3</sup> /hr	12-19 m <sup>3</sup> /hr	12-19 m <sup>3</sup> /hr	20-30 m <sup>3</sup> /hr
<b>Head:</b>	150 mlc	150 mlc	225 mlc	200 mlc
<b>Power:</b>	440 VAC/60 Hz	440 VAC/60 Hz	440 VAC/60 Hz	440 VAC/60 Hz
<b>Max Motor Rating:</b>	6.0 kW	9.0 kW	12 kW	18 kW
<b>NPSHR:</b>	< 0.20 m	< 0.25 m	< 0.25 m	< 0.30 m
<b>Pumpdown:</b>	< 0.15 m	< 0.18 m	< 0.18 m	< 0.20 m
<b>Efficiency:</b>	46%	41%	43%	50%
<b>Weight:</b>	136 kg	150 kg	150 kg	171 kg
<b>Year of Initial Production:</b>	2001	2011	2001	1992
<b>Production Volume:</b>	20	28	70	22

## SAMPLE CURVE – FUEL GAS PUMP WITH VFD

PUMP MODEL NO.	1.25ECC-085	PREFERRED OPERATING REGION	7.2 m <sup>3</sup> /h to 20.3 m <sup>3</sup> /h @ 69.8 m to 342.3 m
ITEM NO.	TBD	ALLOWABLE OPERATING REGION	3 m <sup>3</sup> /h to 22.1 m <sup>3</sup> /h @ 63.9 m to 391 m
PROJECT	TBD	LIQUID	LNG @ -163 deg C
DOC. NO.	PPC-TBD-1	SPECIFIC GRAVITY (SG 1 & SG 2)	0.5 & 0.5
DATE	5-Mar-2018	ELECTRICAL DATA @ RATED	25 kW / 60 Hz / 380 V / 3600 RPM / 3 Phase

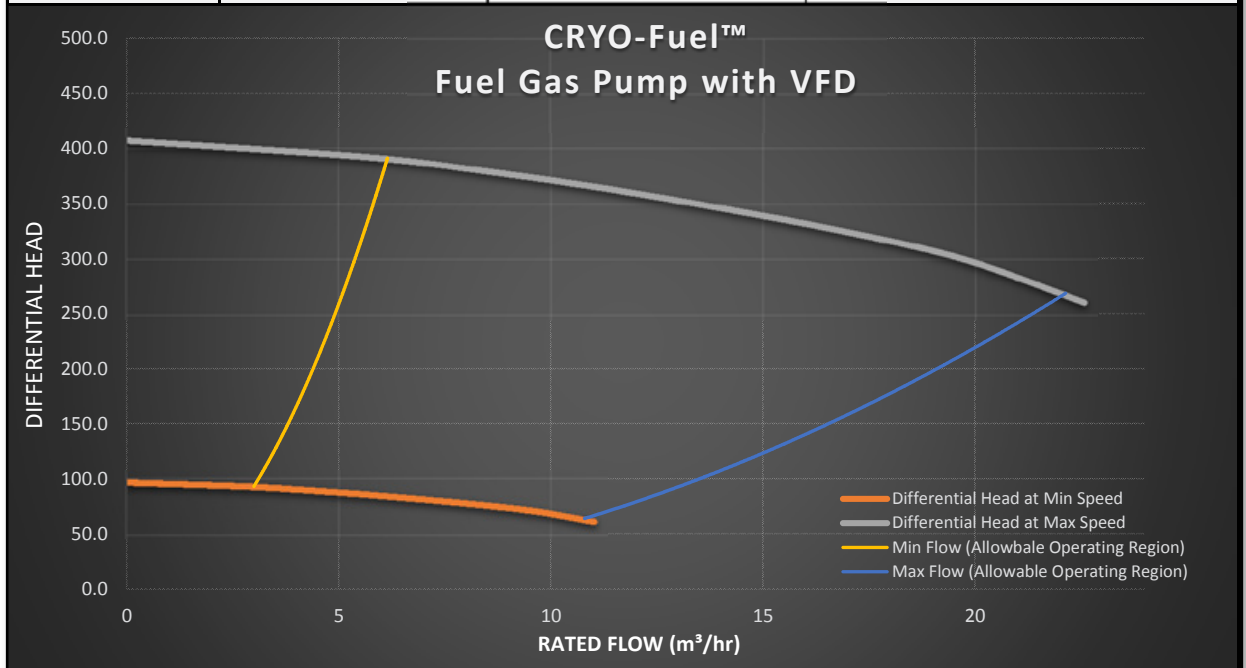

# BUNKERING

## BUNKERING VESSEL AND BARGE APPLICATIONS

To meet the demand in the growing LNG-as-a-Fuel market, bunkering barges and vessels are becoming more common. Cryodynamic Products has smaller capacity cargo pump offerings that can be used for offloading LNG cargo and ship-to-ship (STS) transfers. The available options for cargo pumps include:

- Cargo/offloading pumps
- Stripping/spray pumps
- Dedicated fuel gas pumps
- Emergency pumps

These fixed mounted submerged motor pumps can be installed in membrane tanks and C-type tanks. Adaptations for B-type tanks and prismatic tanks can be incorporated.

Pumps are custom designed to match a wide range of duties and requirements depending on the application. Using our large library of hydraulics, we can provide a cargo pump that will meet your duty point.

The Cryodynamics bunkering cargo pump is designed to operate using a low voltage AC drive. The AC drive is paired with a Cryodynamics motor to generate the pump curves shown here. The AC drive expands the pump allowable operating region so the pump can reach higher pressures and lower capacities not otherwise achievable by a fixed speed pump. Additionally, the AC drive allows the pump speed to be reduced to lower the NPSHR and the liquid level of the tank to the desired low levels. Low voltage AC drives can be supplied for marine applications and designed for remote control systems and pump startup.

Examples of drives that could be used in these applications are:

The Allen-Bradley PowerFlex®\* 750 Series AC Drives:

<http://ab.rockwellautomation.com/Drives/Low-Voltage-AC-Drives>

*\*PowerFlex is a trademark of Rockwell Automation, Inc.*



## SAMPLE ESTIMATED PUMP CHARACTERISTIC CURVE – DIFFERENTIAL HEAD

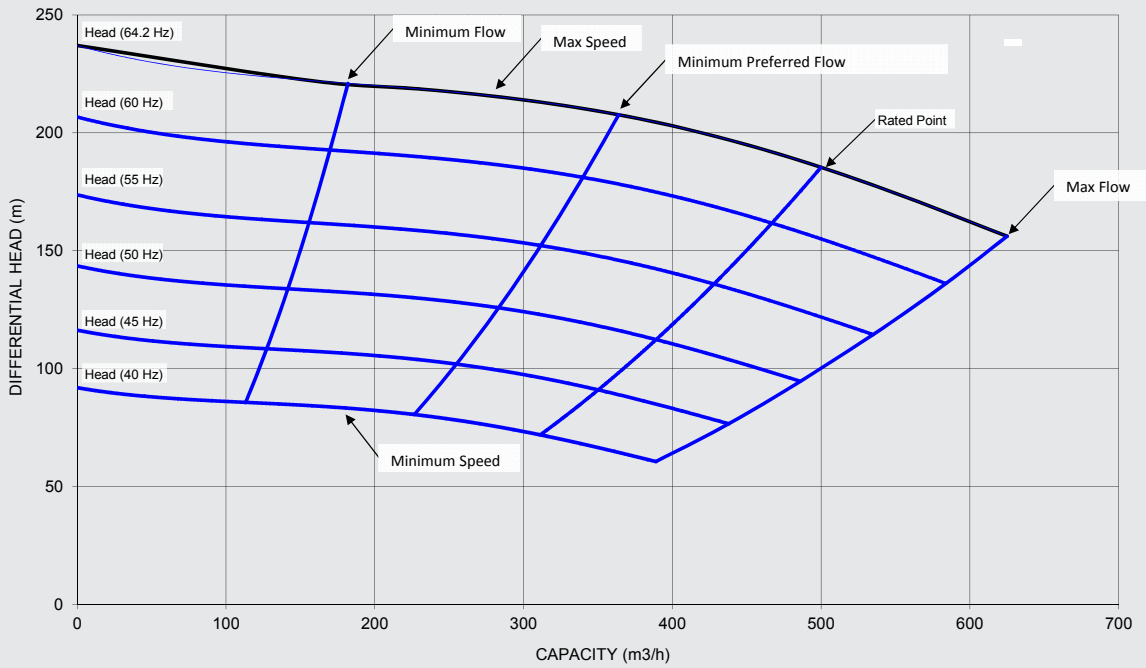

## SAMPLE ESTIMATED PUMP CHARACTERISTIC CURVE – NPSH AND PUMPDOWN

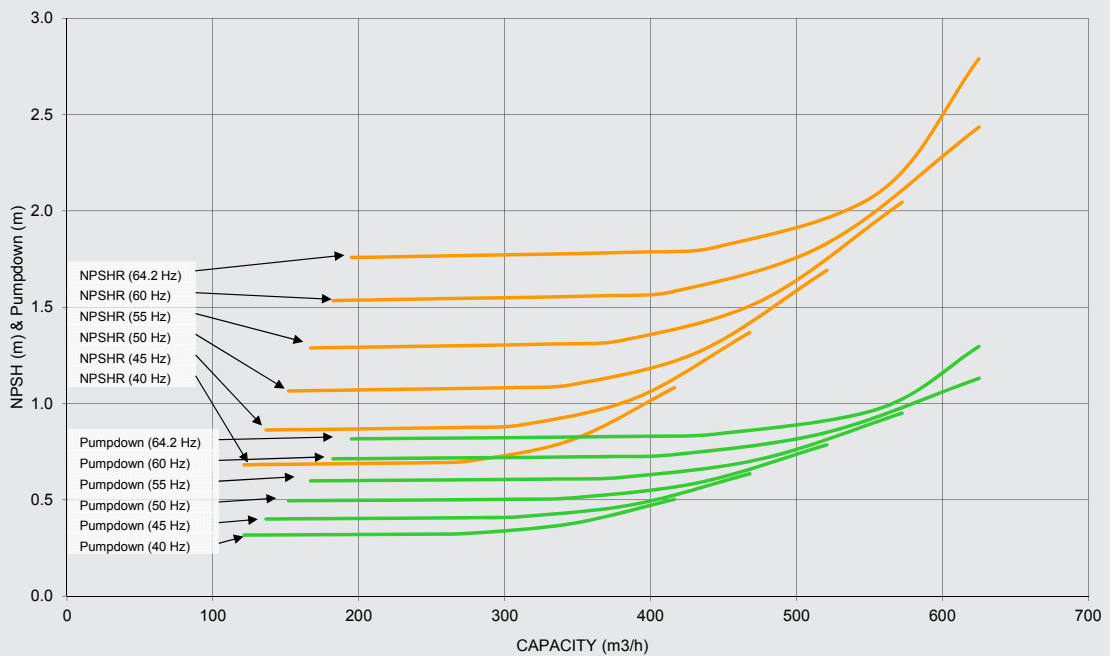

# OPTIONS

## VIBRATION MONITORING SYSTEMS (VMS)

Depending on your project, your VMS can be designed with either a PCB 4-20mA transmitter arrangement or a Bently Nevada 3500 compatible interface module. These packages can meet all of your system or control room needs including:

- Accelerometers
- Instrument rack
- Cabling
- Power supply
- Feedthru(s)
- Monitors
- Junction box
- Cabinet

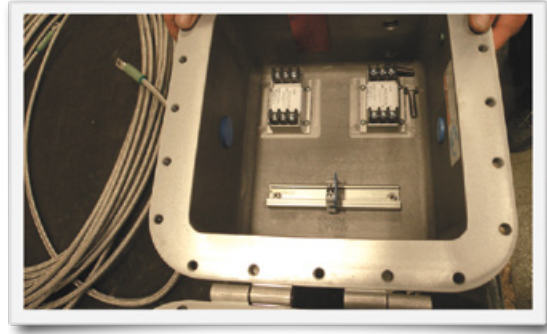

## EQUIPMENT FEATURES/OPTIONS

- Submerged Induction Motors
  - Submerged in oxygen-free cryogenic liquid, removing potential for ignition; no mechanical seals*
- Patented Thrust Equalizing Mechanism (TEM®)
  - Zero thrust load on the bearings for longer life*
- Complete Electrical System Packages
  - VFD, power cables, and junction boxes included*
- Inducers
  - Pumps operate at extremely low NPSH levels without cavitation*
- Performance Testing with Actual Field Operation Conditions
  - We test every pump in LNG for absolute quality assurance*
- Vessel Options
  - Single wall or vacuum insulated*
- Condition Monitoring including Cryogenic ICP® Accelerometers
- Skid Packaging



**SAMSUNG KOREAN LNG CARRIERS FOR QATAR**



**LNG CARRIER AT RAS LAFFAN IN QATAR**



Elliott Group is a global leader in the design, manufacture, and service of technically advanced centrifugal compressors, steam turbines, power recovery expanders, cryogenic pumps and expanders, and axial compressors used in the petrochemical, refining, oil & gas, liquefied gas, and process industries, as well as in power applications.

Elliott Group is a wholly owned subsidiary of Ebara Corporation, a major industrial conglomerate headquartered in Tokyo, Japan.



901 North Fourth Street  
Jeannette, PA 15644-1473  
Telephone: 724-527-2811  
Fax: 724-600-8442  
Email: [info@elliott-turbo.com](mailto:info@elliott-turbo.com)

350 Salomon Circle  
Sparks, NV 89434 USA  
Telephone: 775-356-2796

Email: [info@elliott-turbo.com](mailto:info@elliott-turbo.com)  
[www.elliott-turbo.com](http://www.elliott-turbo.com)

T H E W O R L D T U R N S T O E L L I O T T

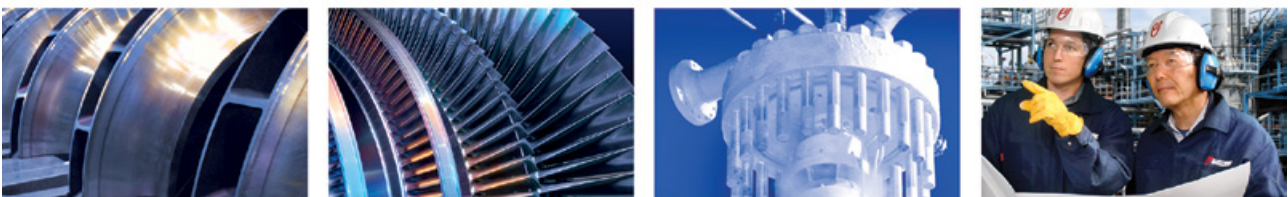

COMPRESSORS ■ TURBINES ■ CRYODYNAMICS ■ GLOBAL SERVICE